

DESIGN SHEET

OLD NAVY

GAP

Style # 54023

Company Name:	GAP
Address:	2 Folsom St., San Francisco, CA 94105
Phone Number:	(650) 952-4400
Fax Number:	(650) 952-4407

GARMENT INFORMATION

Group Name:	Womenswear
Classification:	Women's Jeans
Season:	Stock
Garment Label:	Old Navy
Fabric Content:	70% Cotton, 28% Polyester, 2% Spandex
Colorway:	3401, 3402, 3403
Description:	High-Rise Zipper Fly with Button Closure Five Pocket Rockstar Skinny Fit

SHEET INFORMATION

Date Created:	9/10/18
Date Modified:	9/26/18
Date Released:	9/30/18
Designer Initials:	KS
Page Number:	1
Style Number:	# 54023



Sketch:

Designer Initials: KS

ILLUSTRATION SHEET

OLD NAVY

GAP

Company Name:	GAP
Address:	2 Folsom St., San Francisco, CA 94105
Phone Number:	(650) 952-4400
Fax Number:	(650) 952-4407
Page Number:	2

GARMENT INFORMATION

Group Name:	Womenswear
Classification:	Women's Jeans
Season:	Stock
Garment Label:	Old Navy
Size Ranges:	0 - 2 - 4 - 6 - 8 - 10 - 12 - 14 - 16 - 18 - 20
Style Number:	# 54023
Description:	High-Rise Zipper Fly with Button Closure Five Pocket Rockstar Skinny Fit

FABRIC INFORMATION

Fabric Content:	70% Cotton, 28% Polyester, 2% Spandex
Colorway Number:	

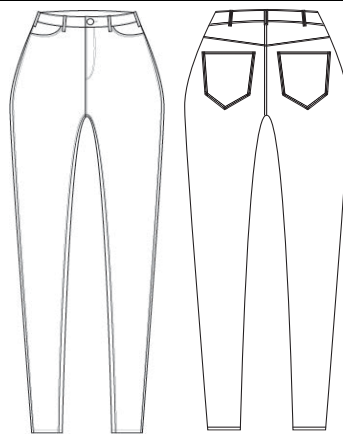

Colorways:

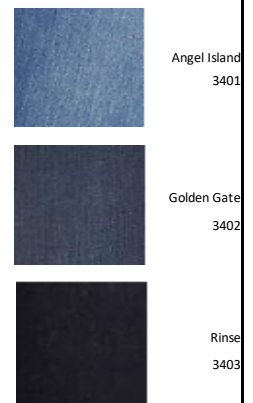

SHEET INFORMATION

Date Created: 9/12/18	Date Modified: 9/26/18	Date Released: 9/30/18	Designer Initials: KS
Comments: *See construction notes			
Page Number: 2			Style Number: #54023



COLORWAY SHEET

OLD NAVY

GAP

Company Name:	GAP	Style Number:	#54023
Address:	2 Folsom St. San Francisco, CA 94105	Group Name:	Womenswear
Phone Number:	(650) 952-4400	Classification:	Women's Jeans
Fax Number:	(650) 952-4407	Season:	Stock
		Colorway:	3401 Angel Island

COLORWAY INFORMATION

Group Name:	Womenswear	Sketch	Swatch
Classification:	Women's Jeans		
Season:	Stock		
Garment Label:	Old Navy		
Size Ranges:	0 - 2 - 4 - 6 - 8 - 10 - 12 - 14 - 16 - 18 - 20		
Style Number:	# 54023		
Description:	High-Rise Zipper Fly with Button Closure Five Pocket Rockstar Skinny Fit		
Fabric Information	70% Cotton, 28% Polyester, 2% Spandex		
Width	60" Wide		

SHEET INFORMATION

Date Created: 9/28/18	Date Modified: 9/30/18	Date Released: 9/30/18	Designer Initials: KS
Comments: *See construction notes			
Page Number: 3			Style Number: #54023



COLORWAY SHEET

OLD NAVY

GAP

Company Name:	GAP	Style Number:	#54023
Address:	2 Folsom St. San Francisco, CA 94105	Group Name:	Womenswear
Phone Number:	(650) 952-4400	Classification:	Women's Jeans
Fax Number:	(650) 952-4407	Season:	Stock
		Colorway:	3402 Golden Gate

COLORWAY INFORMATION

Group Name:	Womenswear	Sketch	Swatch
Classification:	Women's Jeans		
Season:	Stock		
Garment Label:	Old Navy		
Size Ranges:	0 - 2 - 4 - 6 - 8 - 10 - 12 - 14 - 16 - 18 - 20		
Style Number:	# 54023		
Description:	High-Rise Zipper Fly with Button Closure Five Pocket Rockstar Skinny Fit		
Fabric Information	70% Cotton, 28% Polyester, 2% Spandex		
Width	60" Wide		

SHEET INFORMATION

Date Created: 9/28/18	Date Modified: 9/30/18	Date Released: 9/30/18	Designer Initials: KS
Comments: *See construction notes			
Page Number: 4			Style Number: #54023



COLORWAY SHEET

OLD NAVY

GAP

Company Name:	GAP	Style Number:	#54023
Address:	2 Folsom St.	Group Name:	Womenswear
	San Francisco, CA 94105	Classification:	Women's Jeans
Phone Number:	(650) 952-4400	Season:	Stock
Fax Number:	(650) 952-4407	Colorway:	3403 Rinse

COLORWAY INFORMATION

Group Name:	Womenswear		
Classification:	Women's Jeans		
Season:	Stock		
Garment Label:	Old Navy		
Size Ranges:	0 - 2 - 4 - 6 - 8 - 10 - 12 - 14 - 16 - 18 - 20		
Style Number:	# 54023		
Description:	High-Rise Zipper Fly with Button Closure Five Pocket Rockstar Skinny Fit		
Fabric Information:	70% Cotton, 28% Polyester, 2% Spandex		
Width:	60" Wide		

SHEET INFORMATION

Date Created: 9/28/18	Date Modified: 9/30/18	Date Released: 9/30/18	Designer Initials: KS
Comments: *See construction notes			
Page Number: 5			Style Number: #54023

BOM/COMPONENT SHEET



Company Name:	GAP	Style Number:	#54023	
Address:	2 Folsom St. San Francisco, CA 94105	Group Name:	Womenswear	
Phone Number:	(650) 952-4400	Classification:	Women's Jeans	
Fax Number:	(650) 952-4407	Season:	Stock	
		Colorway:	3401, 3402, 3403	
MATERIAL INFORMATION				
Item/Vendor/Code/Origin	Content	Size/Quantity/Unit of Measure	Location/Placement	Color
Body Fabric - Cone Denim - China	70% Cotton 28% Polyester 2% Spandex	60" wide - 1.5 yards	Body fabric	See Colorways
Pocket Bag - Alibaba - Hebei, China	80% Polyester 20% Cotton Poplin	60" wide - 0.125 yard	inside front pocket	Plain White Dyed
Button - WYSE Industrial (Shenzhen) Co. Ltd	Alloy, Brass	17 mm - 1 Button/pair of jeans (Set of 10,000)	Top of zipper placket	Brass
Rivets - Alibaba - Guangzhou Sanko Button	Brass	1 cm - 2 Rivets/pair of jeans (Set of 3000)	Bottom front pockets	Brass
Construction Thread - Sil Thread Inc. (YKK)	100% Polyester	Tex 40 - 6,000 Yards/spool	All construction and merrow	Gold - 510
Topstitching Thread - Sil Thread Inc. (YKK)	100% Polyester	Tex 60 - 750 Yards/spool	All topstitching	Gold - 510
Zipper - A. Feibusch Corp - New York, USA	Brass - 100% Polyester	10.5 cm - 1 Zipper per pair of jeans	Zipper placket	Brass, Navy - 560
Comments:				
SHEET INFORMATION				
Date Created: 9/14/18	Date Modified: 9/26/18	Date Released: 9/30/18	Designer Initials: KS	Style Number: #54023
Comments: *See construction notes				
Page Number: 6				

CONSTRUCTION SHEET

OLD NAVY

GAP

Company Name:	GAP	Style Number:	#54023
Address:	2 Folsom St. San Francisco, CA 94105	Group Name:	Womenswear
Phone Number:	(650) 952-4400	Classification:	Women's Jeans
Fax Number:	(650) 952-4407	Season:	Stock
		Colorway:	3401, 3402, 3403

Operation	Comments
Prepare all pieces to be sewn	All pieces are cut and prepared to be sewn
Sew pocket lining/pocket bag to top	301 Lock Stitch
Topstitch pocket	301 Lock Stitch
Fix pocket bag at side and top	301 Lock Stitch
Set fly facing and topstitch top of fly	301 Lock Stitch
Attach zipper to opposite side of fly	301 Lock Stitch
Topstitch left fly and J stitch	301 Lock Stitch
Set right fly to zip	301 Lock Stitch
Sew crotch seam	512 Mock Safety Stitch
Join sides	516 Class Safety Stitck used for side seams
Matching crotch	512 Mock Safety Stitch - Mock Flat Felled Stitch
Sew and attach back yoke	401 Single Chain Stitch Yoke is attached to top back of jeans
Stitch side seam upper part	Join jeans on side where front pocket was sewn - 301 Lock Stitch
Turning	Turn jeans right-side out
Create Waistband	Create waistband and prepare to attach to jeans
Set waistband	Two-step waistband attached to top of jean front and back yoke - all the way around circumference - 301 Lock Stitch
Cut and open waistband ends	Prepare ends to be closed
Close waistband ends	301 Lock Stitch
Topstitch waistband	401 Single Chain Stitch
Create and cut carriers	One long carrier is created withy 406 Bottom Cover Stitch, then cut into 5 pieces
Sew carriers to top	Belt loop carriers are installed onto the waistband/top of jeans - 300 Bartack stitch is used to secure belt loops to pants
Hem pant legs	Double fold hem - 401 Chain stitch is used on hem
Sew patch pockets to back	Must be prepped first, then attached with 301 Lock Stitch
Topstitch patch pockets to back	301 Lock Stitch
Attach button and rivets	Button goes on fly front; rivets go on front pockets next to side seams
Sew button hole on front fly	304 Zigzag Stitch
Wash jeans for proper finish	Jeans go through stone wash to get worn look
Inspection	Jeans are inspected to ensure quality

Seam Allowances		Placement
Width	1 cm	Inseams and Outseams
Width	9/10 cm	Merrowed edge around fly
Width	1 cm	All flat felled seams
Width	3/5 cm	Pocket lining seams

SHEET INFORMATION

Date Created: 9/12/18	Date Modified: 9/30/18	Date Released: 9/30/18	Designer Initials: KS
Comments: *See construction notes			
Page Number: 7			Style Number: #54023

SPEC SHEET

OLD NAVY

GAP

Company Name:	GAP	Style Number:	#54023
Address:	2 Folsom St. San Francisco, CA 94105	Group Name:	Womenswear
Phone Number:	(650) 952-4400	Classification:	Women's Jeans
Fax Number:	(650) 952-4407	Season:	Stock
		Colorway:	3401, 3402, 3403

SPEC INFORMATION



CODE	POINT OF MEASURE	TOL. +/-	0	2	4	6	8	10	12	14	16	18	20
81	Waistband Depth	0.00 cm	4.10 cm	4.10 cm	4.10 cm	4.10 cm	4.10 cm	4.10 cm	4.10 cm	4.10 cm	4.10 cm	4.10 cm	4.10 cm
83	Waistband Circumference	1.91 cm	74.06 cm	76.60 cm	79.14 cm	79.14 cm	79.14 cm	79.14 cm	80.41 cm	80.41 cm	80.41 cm	80.41 cm	80.41 cm
105	Inseam	0.95 cm	75.18 cm	75.50 cm	76.14 cm	76.14 cm	76.14 cm	76.14 cm	76.14 cm	76.14 cm	76.14 cm	76.14 cm	76.41 cm
106	Outseam	0.95 cm	100.22 cm	99.90 cm	101.17 cm	101.17 cm	101.17 cm	101.17 cm	101.17 cm	101.17 cm	101.17 cm	102.12 cm	102.12 cm
109	High Hip Circumference	1.91 cm	72.32 cm	77.40 cm	82.48 cm	82.48 cm	82.48 cm	82.48 cm	85.02 cm	85.02 cm	85.02 cm	87.56 cm	87.56 cm
109a	Low Hip Circumference	1.91 cm	85.06 cm	87.60 cm	90.14 cm	90.14 cm	90.14 cm	90.14 cm	91.41 cm	91.41 cm	91.41 cm	92.68 cm	92.68 cm
107	Front Rise	0.95 cm	25.07 cm	25.70 cm	26.65 cm	26.65 cm	26.65 cm	26.65 cm	26.65 cm	26.65 cm	26.65 cm	26.97 cm	26.97 cm
108	Back Rise	0.95 cm	37.97 cm	38.60 cm	39.55 cm	39.55 cm	39.55 cm	39.55 cm	39.55 cm	39.55 cm	39.55 cm	39.87 cm	39.87 cm
110	Thigh Width Circumference	0.95 cm	48.73 cm	50.00 cm	51.91 cm	51.91 cm	51.91 cm	51.91 cm	52.54 cm	52.54 cm	52.54 cm	53.18 cm	53.18 cm
112	Knee Width Circumference	0.95 cm	33.77 cm	34.40 cm	35.67 cm	35.67 cm	35.67 cm	35.67 cm	36.31 cm	36.31 cm	36.31 cm	36.94 cm	36.94 cm
109b	Hem Circumference	0.64 cm	23.98 cm	24.30 cm	24.94 cm	24.94 cm	24.94 cm	24.94 cm	25.25 cm	25.25 cm	25.25 cm	25.25 cm	25.25 cm
93	Hip Seat Width Circumference	2.54 cm		95.40 cm									
114	Leg Opening Width Circumference	0.64 cm		26.50 cm									
121a	Fly Opening Length (To Bartack)	0.00 cm		15.60 cm									
121b	Fly Opening Width (Inner Fly)	0.00 cm		13.20 cm									
125	Back Pocket (Applied) Height Center	0.00 cm		14.70 cm									
126	Back Pocket (Applied) Width Top	0.00 cm		15.60 cm									
127	Front Pocket Opening Along Curve	0.00 cm		12.60 cm									
127a	Key Pocket (Applied) Height Center	0.00 cm		7.95 cm									
127b	Key Pocket (Applied) Width Top	0.00 cm		6.05 cm									
130	Belt Loop Length	0.00 cm		6.40 cm									
131	Belt Loop Width	0.00 cm		1.00 cm									
148e	Back Pocket Placement From Waist Center	0.00 cm		2.50 cm									
148f	Back Pocket Placement From CB Seam	0.00 cm		3.00 cm									
148h	Key Pocket Placement From Waist	0.00 cm		5.60 cm									
148i	Key Pocket Placement From CF Seam	0.00 cm		9.80 cm									

Comments:

SHEET INFORMATION

Date Created: 9/17/18	Date Modified: 9/30/18	Date Released: 9/30/18	Designer Initials: KS
Comments:			
Page 8			Style Number: #54023

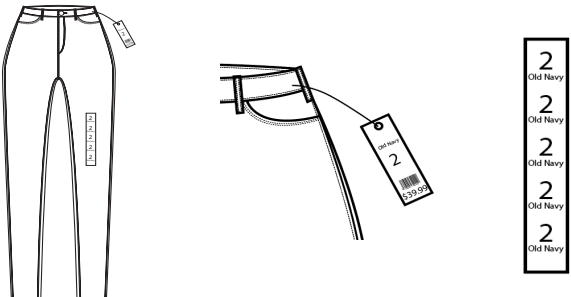
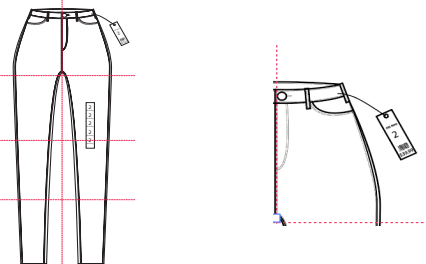
LABELLING AND PACKAGING SHEET			
Company Name:	GAP	Style Number:	#54023
Address:	2 Folsom St. San Francisco, CA 94105	Group Name:	Womenswear
Phone Number:	(650) 952-4400	Classification:	Women's jeans
Fax Number:	(650) 952-4407	Season:	Stock
		Colorway:	3403, 3402, 3403
LABELLING AND PACKAGING:			
Colors:	See Colorways		
Contents:	Women's High Rise Rockstar jeans		
Directions:	Attach hang tag to waistband		
	Attach size sticker to thigh of jeans		
Hang Tag Details:	Hang tag is applied to waistband with an Avery gun		
Packaging Details:	Fold jeans according to Fold Line Directions		
Hang Tag and Size Sticker Placement			
			
PACKAGING INFORMATION			
Fold jeans along lines			
			
SHEET INFORMATION			
Date Created: 9/26/18	Date Modified: 9/27/18	Date Released: 9/30/18	Designer Initials: KS
Comments: *See construction notes			
Page Number: 9			Style Number: #54023

COSTING SHEET

OLD NAVY

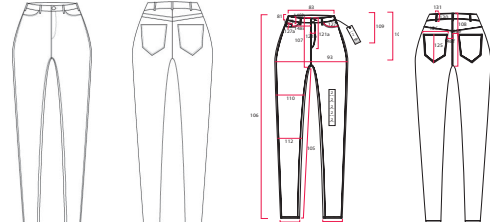

Company Name:	GAP	Style Number:	#54023	Flat Sketch 
Address:	2 Folsom St. San Francisco, CA 94105	Group Name:	Womenswear	
Phone Number:	(650) 952-4400	Classification:	Women's Jeans	
Fax Number:	(650) 952-4407	Season:	Stock	
		Colorway:	3401, 3402, 3403	

COSTING INFORMATION

Material	Vendor/Supplier	Item ID#	Fabric/Pattern Type	Fabric Usage	Cost	Item ID#	Total	
Self	Cone Denim	SP035	Denim - 70% Cotton 28% Polyester 2% Spandex	1.5 yards	\$1.50/yard	SP035	\$2.25	
Lining	Alibaba	Ella242	80% Polyester 20% Cotton Poplin	0.125 yard	\$0.50/yard	Ella242	\$0.06	
							Total:	\$2.31
Finishing	Vendor	Finish ID#	Finish Proces		Cost	Finish ID#	Total	
Stone Wash			Stone Wash		\$0.00		\$0.00	
							Total:	\$0.00
Sundries	Supplier	Item ID#	Type of Sundry	Quantity	Cost	Item ID#	Total	
Buttons	WYSE Industrial (Shenzhen)	J001	Brass Button	1 Button per pair of jeans	\$0.03	J001	\$0.03	
Rivets	Alibaba - Guangzhou Sanko	H65	Brass Rivet	2 Rivets per pair of jeans	\$0.03	H65	\$0.06	
Zipper	A. Feibusch Corp - New York	1471	YKK Zipper	1 Zipper per pair of jeans	\$0.80	1471	\$0.80	
							Total:	\$0.89
Thread	Supplier	Item ID#	Type of Thread	Amount	Cost	Item ID#	Total	
Body/Merrow Thread	Sil Thread Inc. (YKK) - New York	150 - 40	Tex 40	6,000 Yards/spool	\$5.00	150 - 40	\$5.00	
Topstitching Thread	Sil Thread Inc. (YKK) - New York	150 - 60	Tex 60	750 Yards/spool	\$3.75	150 - 60	\$3.75	
							Total:	\$8.75
Labels	Supplier	Item ID#	Type of Label	Quantity	Cost	Item ID#	Total	
Care Labels	Alibaba - NF Sports	NF2715	Care Label	1 per pair of jeans	\$0.01	NF2715	\$0.01	
Hang Tag	Guangzhou Hongtu Garment	L006	Hang Tag	1 per pair of jeans	\$0.01	L006	\$0.01	
Size Sticker	Shanghai Lingfeng Industry	ISO9001	Size Sticker	1 per pair of jeans	\$0.01	ISO9001	\$0.01	
							Total:	\$0.03
Packaging	Supplier	Item ID#	Type of Packaging	Amount	Cost	Item ID#	Total	
Folded - See Packaging							\$0.00	
							Total:	\$0.00

LABOR	S.A.M.	Rate	Total	Misc	Company	\$ Per Dozen	\$ Per Garment
Sewing	45 minutes	\$68.00/month	\$0.45	Duty	Transfast	\$4.44	\$0.37
Printing/Dyeing	\$0.00	\$0.00	\$0.00	Quota	INCL	\$0.00	\$0.00
Trimming	\$0.00	\$0.00	\$0.00	Freight	FashExpress	\$1.50	\$0.12
Finishing	\$0.00	\$0.00	\$0.00	Handling	INCL	\$0.00	\$0.00
Labelling	12 minutes	\$4.00	\$0.80	Warehousing	NONE	\$0.00	\$0.00
Packaging	6 minutes	\$4.00	\$0.40	Operating	INCL	\$0.00	\$0.00
Other	\$0.00	\$0.00	\$0.00	Insurance	Kminsurance	\$0.14	\$0.01
Total Labor				\$1.65	Total Misc.		\$0.50

SHEET INFORMATION

Date Created: 9/26/18	Date Modified: 9/26/18	Date Released: 9/30/18	Designer Initials: KS
Comments: *See construction notes			
Page Number: 10			Style Number: #54023

FINAL COSTING SHEET

OLD NAVY

GAP

Company Name:	GAP	Style Number:	#54023
Address:	2 Folsom St.	Group Name:	Womenswear
	San Francisco, CA 94105	Classification:	Women's Jeans
Phone Number:	(650) 952-4400	Season:	Stock
Fax Number:	(650) 952-4407	Colorway:	3401, 3402, 3403

COSTING INFORMATION

Cost of Materials:	\$11.98	
Cost of Labor:	\$1.65	
Overhead:	\$3.41	
SubTotal:	\$17.04	
Manufacturer Profit:	\$7.67	
Wholesale Price:	\$24.71	
Total Retail Cost:	\$39.99	

SHEET INFORMATION

Date Created: 9/27/18	Date Modified: 9/30/18	Date Released: 9/30/18	Designer Initials: KS
Comments: *See construction notes			
Page Number: 11			Style Number: #54023